

Physics 120 Final - 13 June 2019

Your name:

Your PID:

You will have one hour to complete this examination.

Please write your answers on a separate sheet of paper, and make sure to put your name and PID on the top of the page.

Staple this sheet as the cover page and give the packet to one of the TAs at the end of the examination.

You are allowed to reference the course website, Gradescope (for your graded laboratory reports and homework), any digital notes you brought using the laboratory computer, and any paper notes you brought with you.

Please do not search the internet for anything besides the course website and Gradescope during the exam.

Please do not discuss this exam with your classmates until after 12:00 noon today, i.e., after everyone in the class has finished the examination.

Please wait and do not turn this sheet over until you are instructed to begin the exam.

Good luck and have a wonderful summer!

Design, build, and characterize a common emitter transistor amplifier

Follow the planning procedure in "Notes on common emitter transistor amplifier" and your related laboratory exercise and homework exercise from week eight.

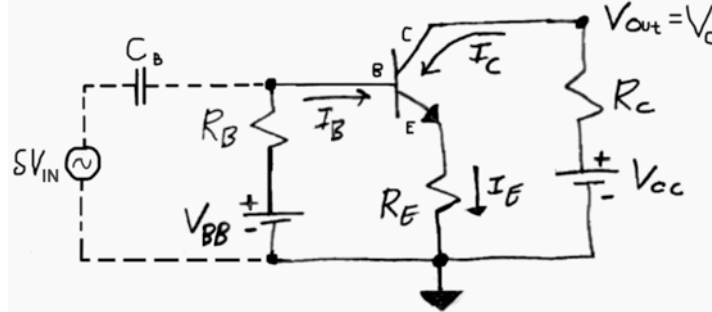

Design an amplifier with a peak amplification of $|V_{out} \setminus V_{in}| = 20$.

- Use a 2N3904 NPN transistor and assume a gain of $\beta = 100$.
Hint: Measure V_{BE} before you start to build.
- Set $V_{CC} = 10.0$ V.
- Choose $V_{CE,Q} = (V_{CC} - V_{CE,Sat})/2 = (10.0 - 0.2)/2 = 4.9$ V.
- Choose $I_{C,Q} = 5$ mA.

DESIGN PHASE

1. **[3 pts]** Determine values of resistors R_C , R_E , and R_B so that the gain is essentially independent of the value of β .
Hint: Use the load-line equation to estimate R_C , then pick R_E , and then pick R_B .
2. **[3 pts]** Sketch the load line and set point on top of the constitutive relation (I_C versus V_{CE}) for the transistor. Mark the Q-point.
3. **[2 pts]** Determine V_{BB} , then convert from a dual to a single power supply.

--- Call a TA to check your plan ---

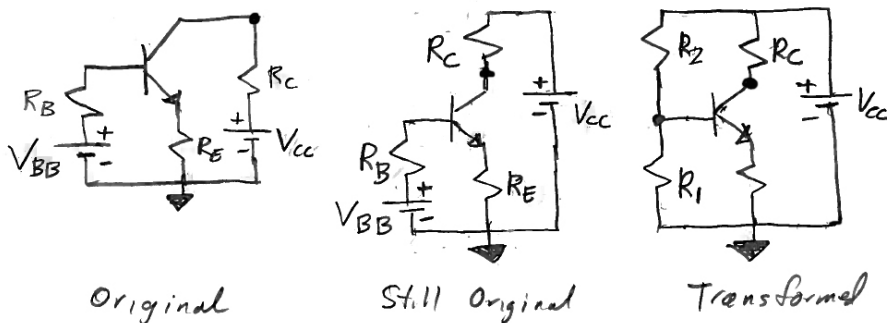

BUILDING PHASE

4. **[5 pts]** Construct the single power supply amplifier. Measure $V_{Emitter}$ and calculate $I_{C,Q} \approx V_{Emitter} / R_E$. Are you close to $I_{C,Q} = 5$ mA?
Hint: Check all components with the multi-meter before you start to build
5. **[4 pts]** Choose $C_B = 1.0$ μ F. Show that the output is reasonably symmetric. Measure high-pass frequency f_{3dB} break. What value did you expect?
Hints: Start your test with an amplitude of ~ 100 mV for V_{in} . Use a probe at V_{out} and set this oscilloscope channel to "AC" coupling.

--- Call a TA to check your measurements ---

6. **[3 pts]** Plot the measured values of $|V_{out} \setminus V_{in}|$ versus frequency on log-log scales (Bode plot) for $f = 10, 20, 50, 100, 200, 500, 1,000, 2,000, 5,000$ and $10,000$ Hz.